

## Optocouplers Isolate Modem Data Access Arrangement

Laptop, palmtop, and pen-based computer modem manufacturers are seeking ways to accommodate the small form factor of the PCMCIA peripheral cards. They are looking for devices to replace the bulky magnetic and electromechanical components normally found in the modem's telco line interconnection. Modem suppliers have found that optocouplers satisfy both the space and performance needs of a PCMCIA format fax/modem product. This application note describes various DAA circuit architectures\*. It shows how the IL350 linear optocoupler, is used to isolate the modem signal, provide ring detection, and Off/Hook operation. The IL350 offers the PCMCIA modem designer a small package with wide signal bandwidth and high insulation and isolation.

### DATA ACCESS ARRANGEMENT - DAA

Figure 1 shows the block diagram of the data-access arrangement (DAA) direct connect modem. The line interconnect section consists of the Off/Hook relay, ring detector, signal isolation, line current sink, and surge protection. An optically coupled FET switch, such as the LH1056, is commonly used for Off/Hook switching. Ringer signal sensing is done by phototransistor optocouplers such as 4N35 or ILD255.

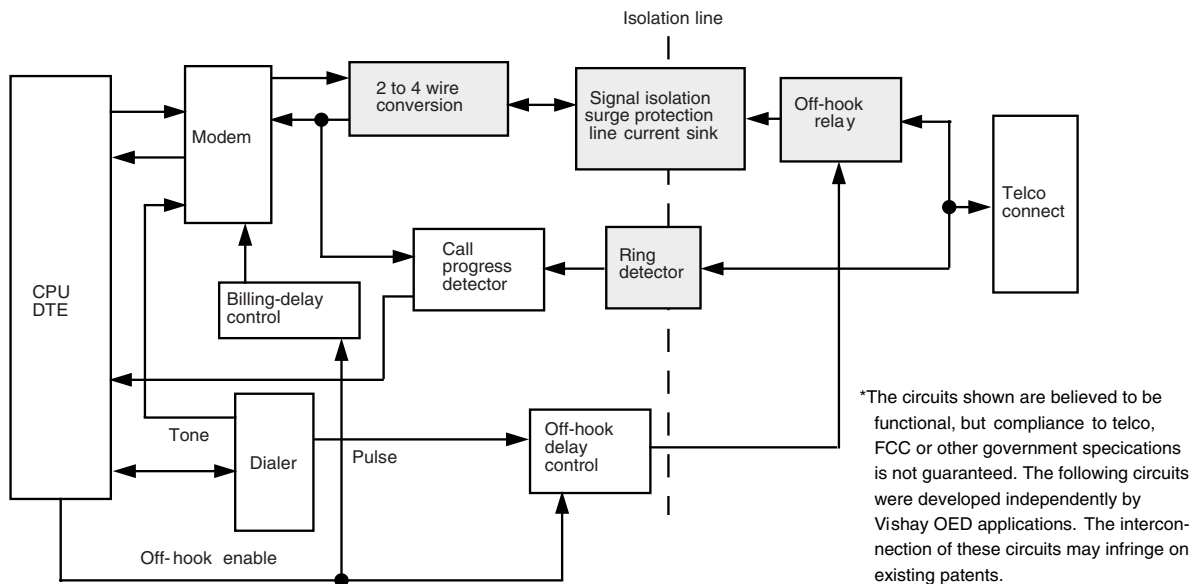

17794

Fig. 1 - DAA-Direct Connect Modem

### OPTICAL 2 TO 4 WIRE HYBRID

Replacing the 600  $\Omega$  transformer is the most obvious application of the IL350. When a single baud rate modem is being designed, the IL350 can provide line isolation and also can function as the 2 to 4 wire hybrid.

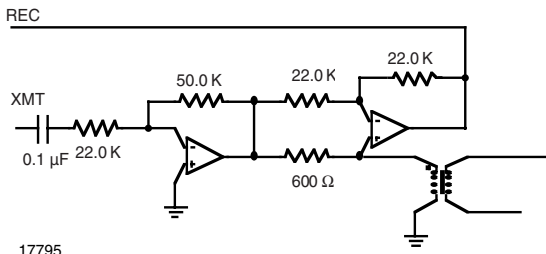

17795

Fig. 2 - 2 to 4 Wire Electronic Hybrid

A typical transformer coupled 2 to 4 wire electronic hybrid is

shown in figure 2. This circuit provides transmitted tone cancellation, while supplying a - 3 dBm transmit level, and receiver sensitivity for a - 42 dBm signal. It offers a 600  $\Omega$  termination impedance to the telco transformer in both transmit and receive function. The hybrid function is provided by U2. When a telco signal is being received the transformer sees a 600  $\Omega$  load, R3, terminated to virtual ground. U2 amplifies the receive signal across R3 with a gain specified by the values of R1 and R4. The modem's transmit signal is canceled by U2's differential amplifier action. The amplifier inverting gain is set so that the feedback signal is equal and 180° out of phase to the transmit signal level arriving at U2's non-inverting input. R1 is selected to set U2's gain. The magnitude of transmit tone cancellation is described in the following equation. Optimum tone cancellation is achieved when  $R3 = R2$  and  $R1 = R4$ .

Transmit suppression

$$(dB) = 20\text{Log}\left\{\text{Abs}\left[\frac{R1 + R4}{R1}\left(\left(\frac{R3}{R1 + R3}\right) - \left(\frac{R4}{R1 + R4}\right)\right)\right]\right\}$$

Figure 3 is a block diagram of an optical transformer connected between the output U1 and the non-inverting input U2. By introducing two unity gain isolation amplifiers in this path, it is possible to isolate the 600 Ω line termination resistor while preserving the hybrid's tone cancellation feature. Figure 4 is a detail of figure 3.

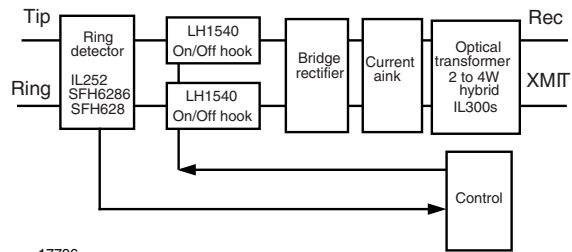

Fig. 3 - DDA/2

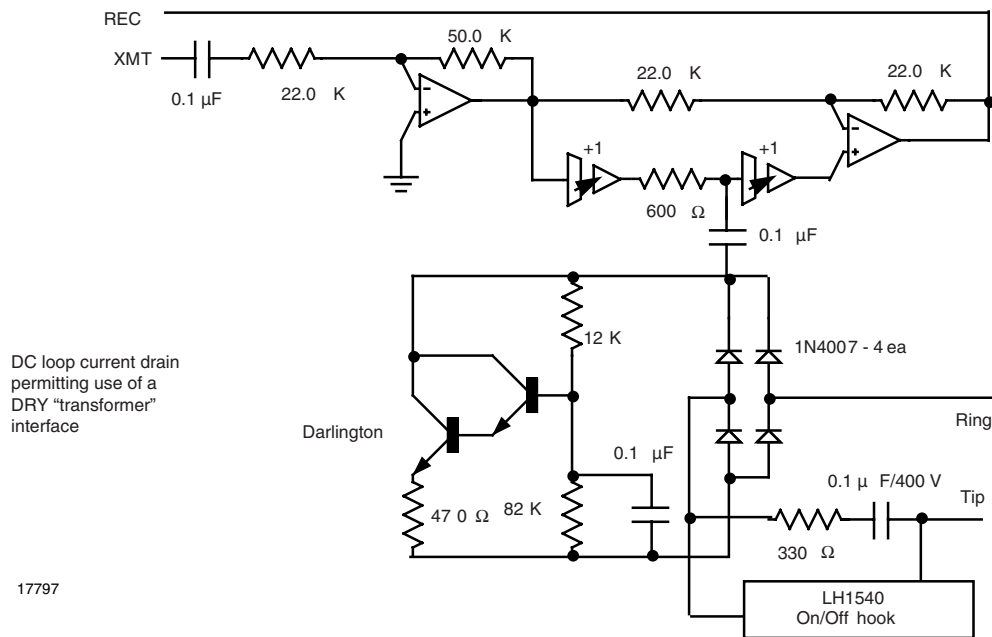

Fig. 4 - 2 to 4 Wire Hybrid Optically Isolated Transformer

Application of the optical transformer results in a "Dry Transformer" type line termination. A dry transformer requires a separate central office battery current return path, which is usually a current sink constructed with discrete components. This example shows a Darlington transistor current sink providing this path.

Various optical transformer 2 to 4 hybrid circuits were investigated. One circuit used single-supply Thevenin style differential operational amplifiers in the isolated section of the interface. The results were less than acceptable. These circuits had difficulty driving reactive low-impedance (600 Ω) loads.

Figure 5 shows a better performing design that uses Norton or current input operation amplifiers (LM3900) in the isolated telco line and standard Thevenin Dual supply operational amplifiers (LM324) within the subscriber unit. The LM3900, U6, easily drives the IL350's LED, and a non-inverting photodiode amplifier requires a minimum of components, U5. Note that U3, LM324, requires a buffer transistor (2N3906) to adequately drive the LED. U4 is used as a trans resistance amplifier, converting the receive IL350's photocurrent into a voltage that is compatible with the

cancellation requirements of U2. The R3, R4, C1 forms the lag compensation network to compensate for the delay in the isolated path between U1's output and U2's input.

A lower component count circuit is shown in figure 5. This interface uses Norton amplifiers exclusively for both the telco line and subscriber instrument sections. The transmit and receive sections are identical to those in figure 4. The transmit suppression is accomplished in the current differential amplifier, U2. R4, R5, C2 form the lag network to compensate for the delay introduced by U3, U4, U5, U6, and U7. 2 to 4 wire optically coupled hybrid Norton amplifier configuration

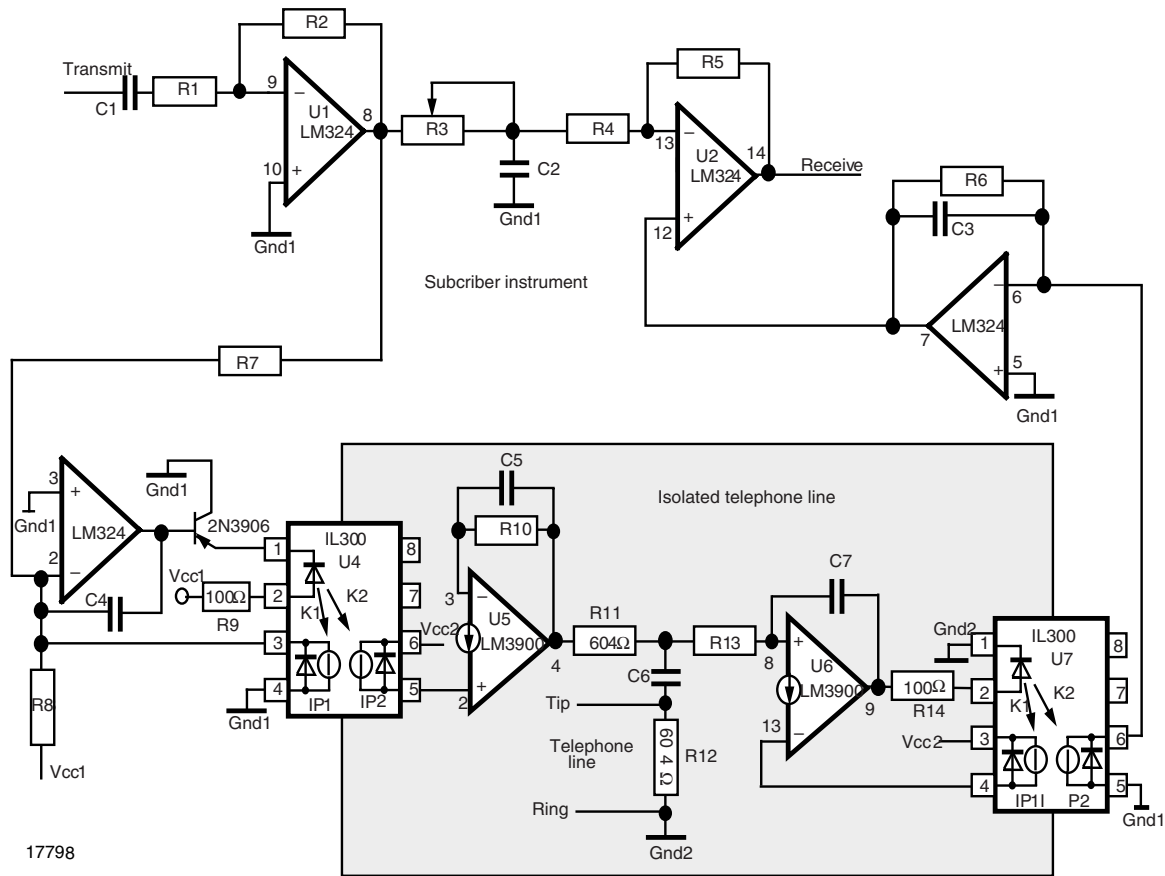

17798

Fig. 5 - 2 to 4 Wire Optically Coupled Hybrid Norton/Thevenin Amplifier

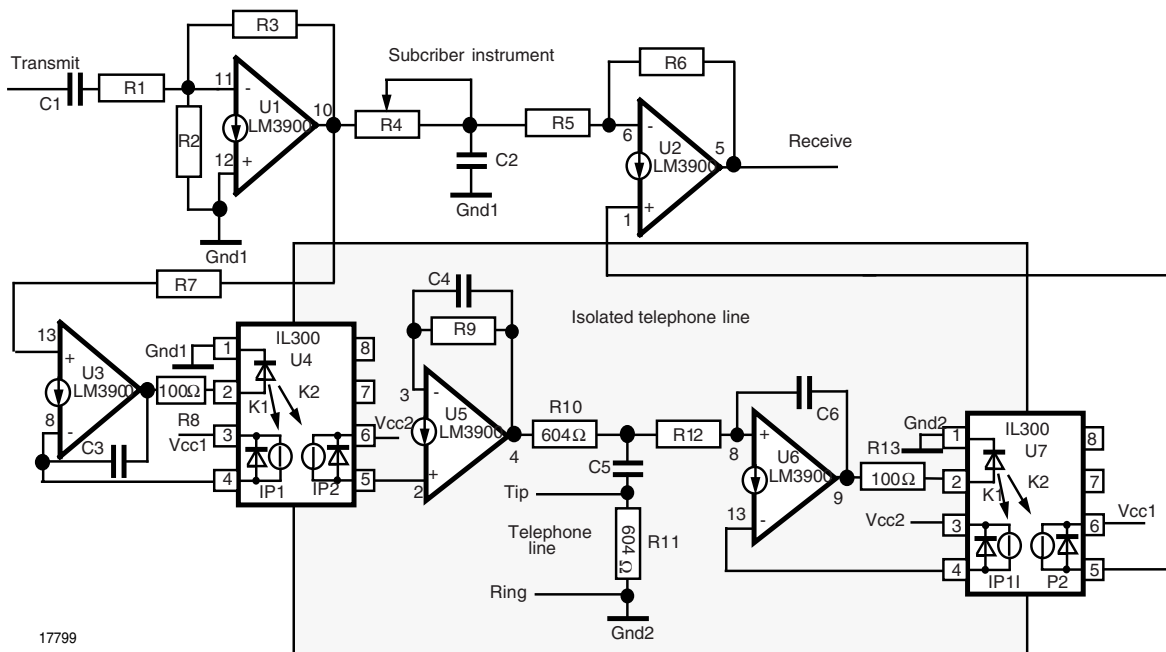

17799

Fig. 6 - 2 to 4 Wire Optically Coupled Hybrid Norton Amplifier Configuration

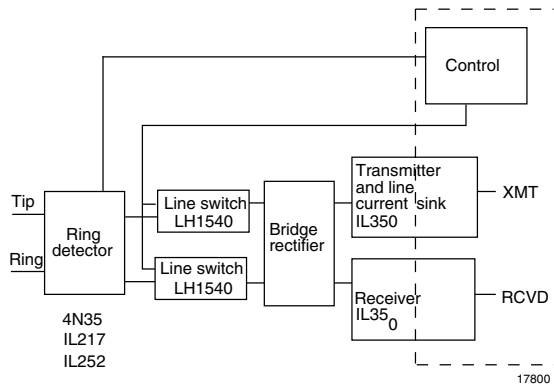

Fig. 7

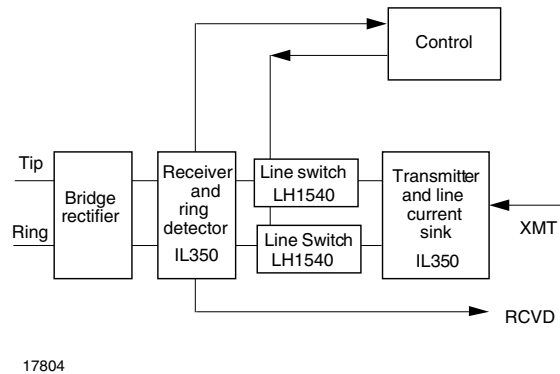

Fig. 8

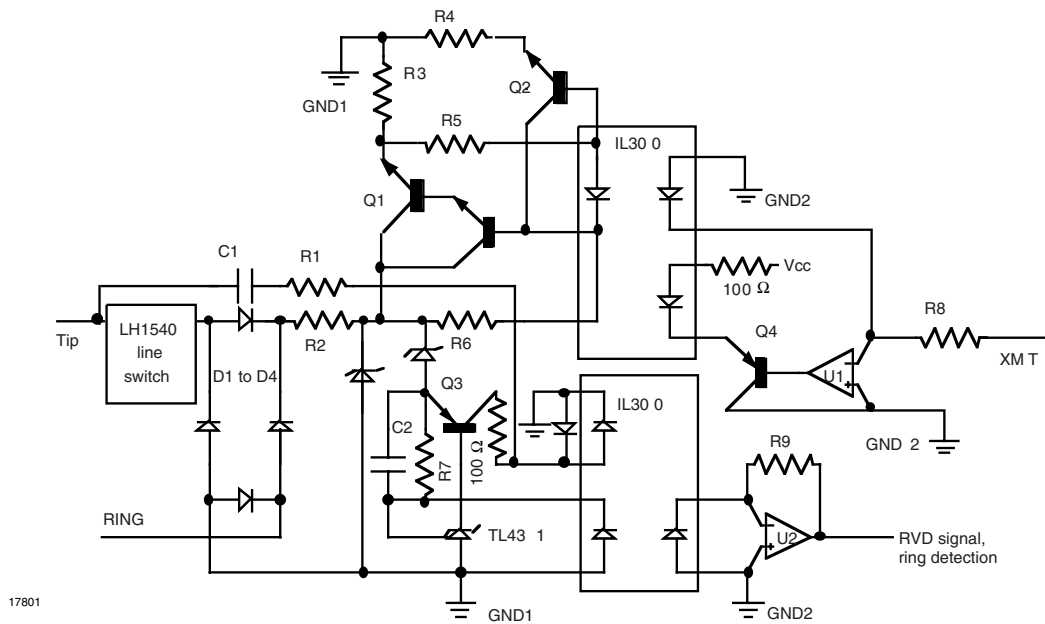

Fig. 9

A 1 kHz transmit signal suppression of -36 dB was measured on the bench. Both of these optical hybrids derive their power from the telco line through a voltage dropping network connected after the off/hook switch. The circuits were evaluated with 5 V to 9 V supply voltages.

### NON HYBRID DAA ARCHITECTURES

The previous circuits may not be suitable for multiple baud rate applications. This results from the frequency dependency of the lag network found in the hybrid. This situation leads to a series of architectures that use digital transmit suppression techniques. When such techniques are possible then standard IL350 interface circuits can be used. Figure 7 shows a design with a phototransistor coupler as the ring detector and one or more LH1540 or LH1546 switches for Off/hook control.

This design can be simplified by having ring detection performed by the IL350 receiver, using one LH1540 or LH1546 off/hook switch and combining the transmitter and line current into one circuit function. The block diagram for

this approach is shown in figure 8, the schematic in figure 9. The circuit operation is as follows. Line off/hook control is performed by one LH1540 or LH1546 FET switch. Ring detection is accomplished by the signal path of C1, R1 and the LED of the IL350 coupler. These values are selected to provide a 1 mA to 2 mA LED ringing current.

Once the ringing signal is detected the off/hook control closes the LH1056, and the IL350 receiver amplifier is energized from power supplied by the central office battery via the bridge rectifier D1-D4. The zener diode ZD2 is used to supply +15 V. The IL350 servo amplifier is constructed with Q3 and a shunt regulator, TL431. R7 is used to set a pre bias current for the servo operation. The optical servo current can range from 50  $\mu$ A to 100  $\mu$ A depending on the K1 servo gain of the IL350. This photo bias current will result in a LED current of 5 mA to 10 mA. C2 provides a low-impedance received signal path into the input of the TL431. The received signal is converted to an output photocurrent based upon the transfer gain, K3, of the IL350. This output photocurrent is then amplified by the trans resistance amplifier, U2.

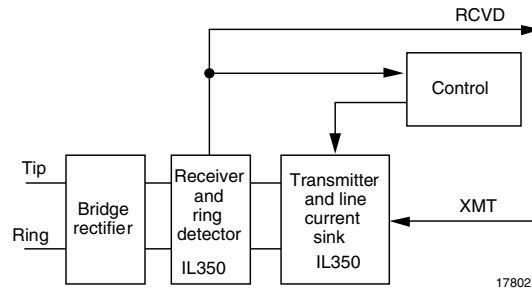

Fig. 10 - Switchless DAA Interconnection

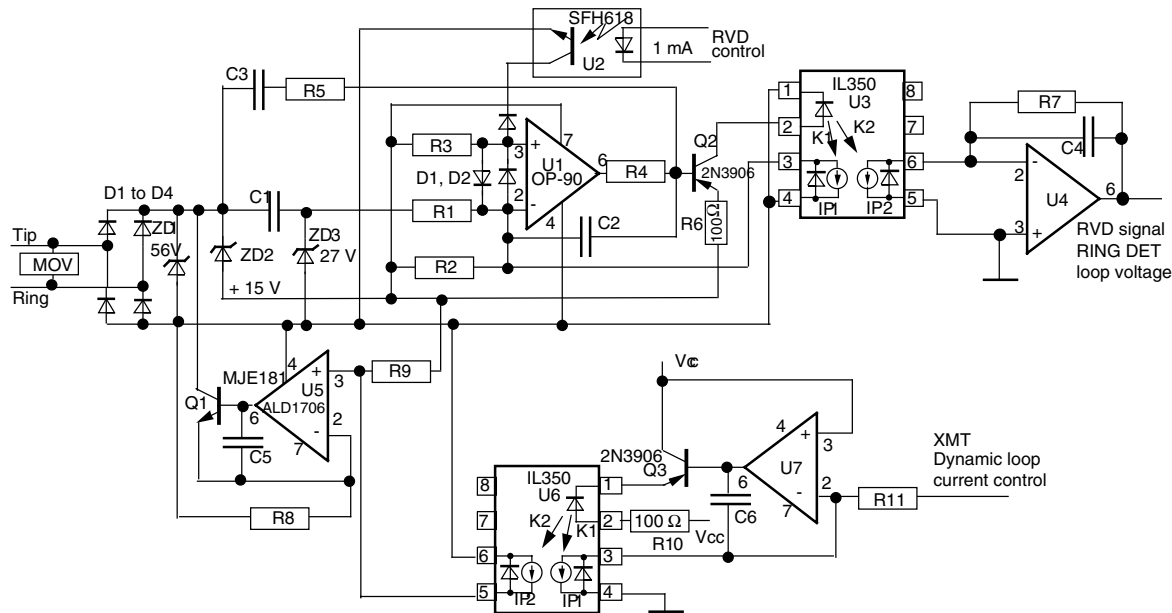

Fig. 11 - Switchless DAA Interconnection

The transmit function and central office battery current sink is provided by the transmit amplifier. This circuit consists of Q1, Q2, R2, R4, R5, and R6. Under transmit operation the transmit signal XMT consists of a DC and AC component. The DC component pre biases the transmit amplifier. This pre bias sets the supplemental line current to be sunk. Recall that the receiver amplifier will require a 5 mA to 10 mA operating current, therefore the transmit current sink will handle any additional current required by the central office switch. The central office line current is typically 20 mA to 30 mA. The AC component of the transmit signal is set to a level that satisfies the -3 dBm line transmit level. This circuit was designed to use the smallest and the fewest number of components as possible. See figure 10 for a circuit design that further minimizes board space by eliminating the off/hook optocouplers. The schematic of this design is shown in figure 11. The circuit operation for this design is as follows. Ring detection is performed by a network consisting of C3, R5, Q2, and the LED of the IL350. This ringer offers a higher impedance than previous designs. This was done to reduce the value and physical size of C3. During ringing, Q2

functions as a ringer amplifier for the LED. Once the ringing signal has been recognized by the modem, the receiver amplifier is activated by turning ON the SFH618 optocoupler, U2. When U2 is Off, it disables a bias network which also disables the micro-power opamp, U1. Under this condition this amplifier requires only a 20  $\mu$ A supply current, equivalent to an Off/Hook resistance of 2.5 M $\Omega$ . When the U2 is ON, it provides a current return for the photo bias current supplied by R2 and R3. This bias network is selected to set an LED quiescent current of 5 mA to 10 mA. The received signal is supplied to U1 via C1 and R1. These values are selected to satisfy the bandwidth and signal to noise requirement of the modem. The received signal generates a modulated LED current that is optically coupled through U3 to the modem receive trans resistance amplifier consisting of U4, C4, and R4. The transmit and central office battery current sink is provided by the transmit amplifier. The transmit amplifier and current sink are connected across the telco line. The transmit signal consists of a DC and AC component. When not transmitting, the transmit signal will have a DC level that forces the LED current of transmit IL350, U6, to zero. Under



this condition the output photocurrent,  $I_{P2}$ , of U6 will also be zero, disabling the transmit amplifier U5 and Q1.

When disabled, the transmit amplifier requires a supply current of less than  $10 \mu\text{A}$ , giving the line an off-hook resistance of  $5 \text{ M}\Omega$ .

When the modem is transmitting, the transmit signal, XMT, will have a DC component sufficient to force Q1 to sink any additional central office line current not required by the activated receive amplifier. U5 and Q1 function as a current to current amplifier. The trans conductance of the amplifier is set by R8, and R11. The transmit AC signal level at U7 is set to provide a -3 dBm signal to the telco line. R9 provides the output photodiode bias return path. The bandwidth of the transmit circuit is set by amplifier selection, with the values of R11, R8, and C6. Signal bandwidths in excess of 20 kHz are possible with proper component selection.

### CONCLUSION

The circuit designs shown in this application note are provided as a starting point for the design of PCMCIA compatible modems. By using the special lead-formed IL350, SOT23, and SOT223 transistors, surface-mount ICs and passive components, a DAA interface that will fit the 5 mm height form factor of the PCMCIA standard can be constructed.